

OPPOSED BLADE DAMPER DUCT MOUNTED

BLADES ON 1" CENTERS & MOUNTED IN CONJUNCTION WITH
SCREW DRIVER OPERATED ADJUSTING MECHANISM.
ALL OBD BLADES RUN SHORT DIMENSION.

EXTRUDED ALUMINUM; 6063-T5

FINISH - MILL - AS EXTRUDED

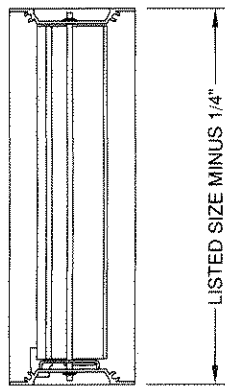
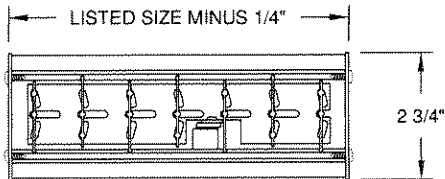
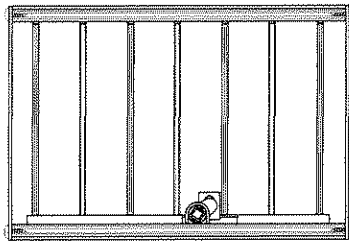

MODEL - OBD-DM

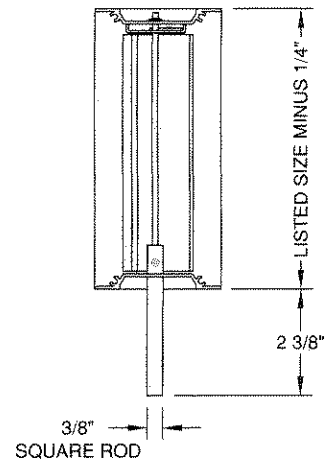
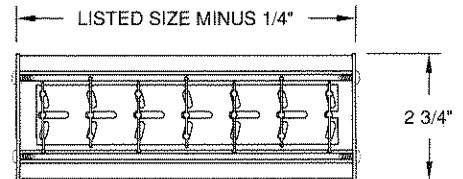
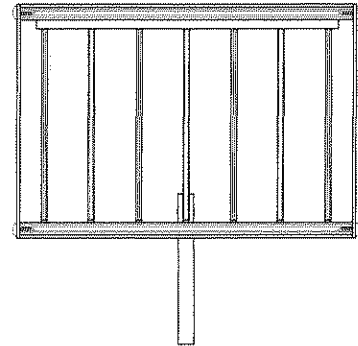

MODEL - OBD-RD-DM - ROD OPERATOR

DWG NO.

02HV185A

JOB NAME: _____

ENGINEER: _____

DATE:

6/19/02

LOCATION: _____

CONTRACTOR: _____

ARCHITECT: _____

FINISH: _____