

RETURN FILTER GRILLE

BLADES SET IN STRAIGHT POSITION ON 3/4" CENTERS WITH FILTER RACK

MINIMUM SIZE: 6" WIDTH x 4" HEIGHT

MAXIMUM SIZE: 96" WIDTH x 48" HEIGHT

GRILLES 48" AND OVER WILL HAVE TWO INNER GRILLES IN ONE OUTER FRAME

EXTRUDED ALUMINUM; 6063-T5

FINISH - SA (CLEAR ANODIZE) OR W (WHITE PAINTED)

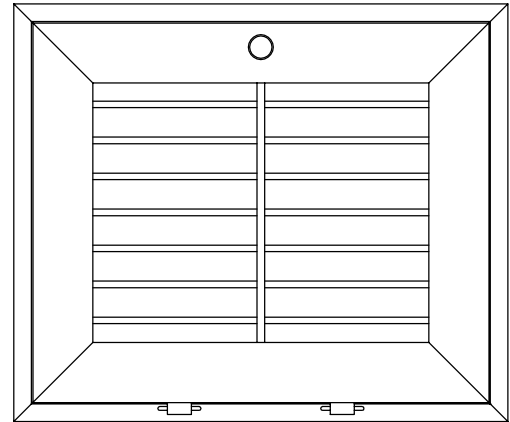

FACE VIEW

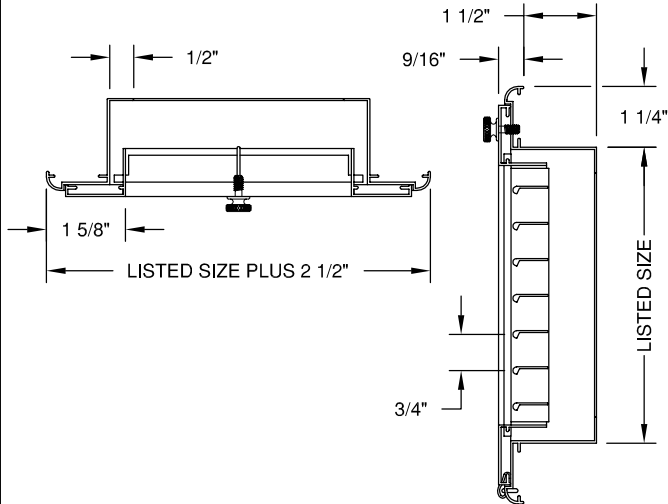

MODEL - GFXFS - 1" FILTER RACK

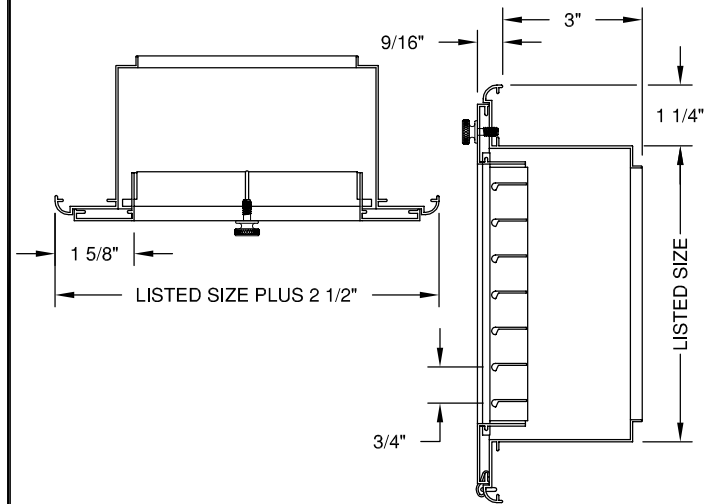

MODEL - GFXFS - 2" FILTER RACK

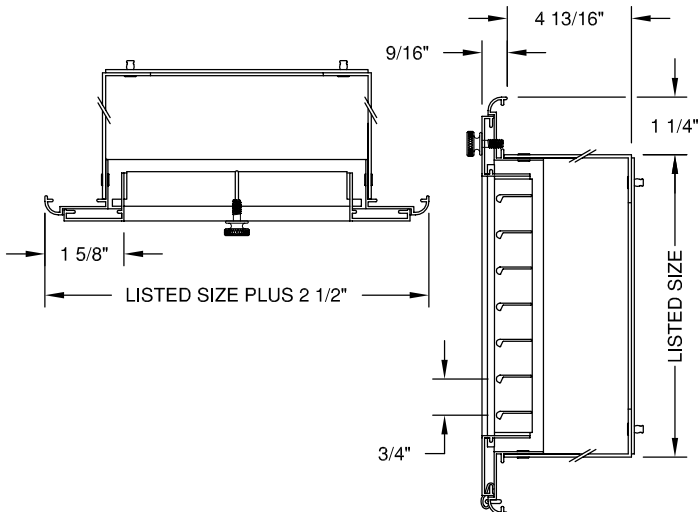

MODEL - GFXFS- 4" FILTER RACK

DWG NO.

02HV065D

JOB NAME: _____

ENGINEER: _____

DATE:

2/12/03

LOCATION: _____

CONTRACTOR: _____

ARCHITECT: _____

FINISH: _____