

CURVED BLADE CEILING DIFFUSERS

INDIVIDUALLY ADJUSTABLE BLADES ON 1" CENTERS
 3-WAY AIR DISTRIBUTION: 1/2 TO FRONT, 1/4 LEFT,
 1/4 TO RIGHT

MINIMUM SIZE: 6" WIDTH x 4" HEIGHT

MAXIMUM SIZE: 36" WIDTH x 36" HEIGHT

EXTRUDED ALUMINUM; 6063-T5

FINISH - SA (CLEAR ANODIZE) OR W (WHITE PAINTED)

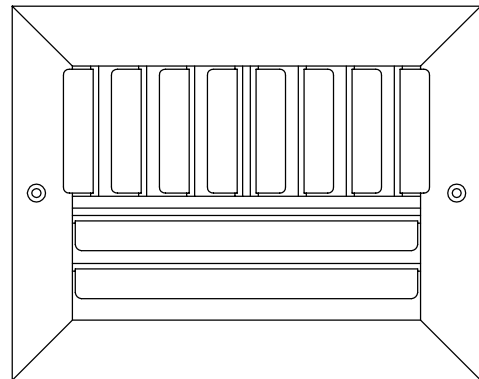

FACE VIEW

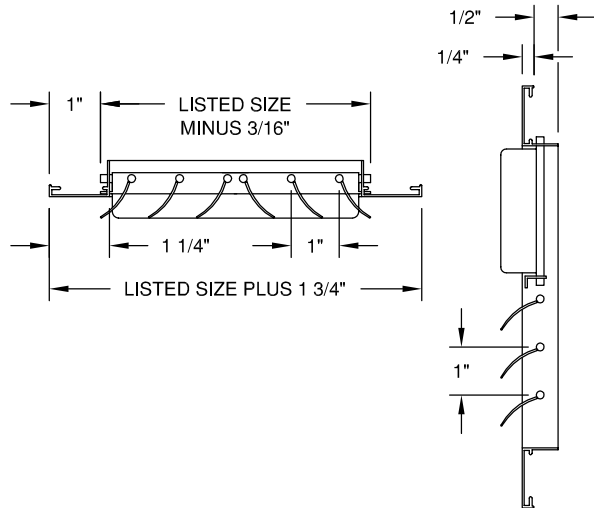

MODEL - C3244 - GRILLE

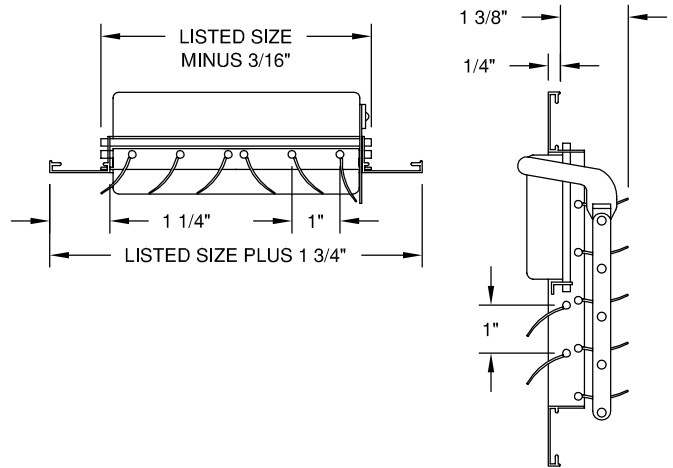

MODEL - C3244M - MULTI-SHUTTER DAMPER

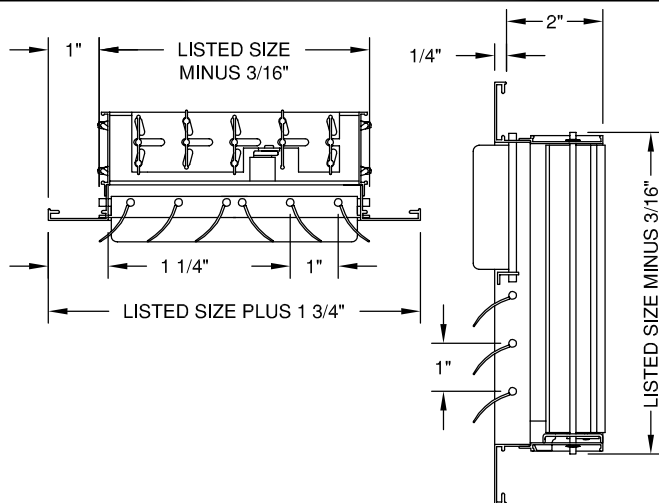

MODEL - C3244O - OPPOSED BLADE DAMPER

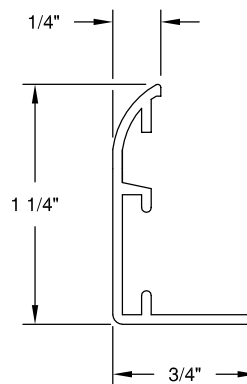

ALTERNATE "Z" FRAME

DWG NO.

02HV009

JOB NAME: _____

ENGINEER: _____

DATE:

9/20/01

LOCATION: _____

CONTRACTOR: _____

ARCHITECT: _____

FINISH: _____