

CURVED BLADE CEILING DIFFUSERS

INDIVIDUALLY ADJUSTABLE BLADES ON 1" CENTERS
 3-WAY AIR DISTRIBUTION WITH CENTER BLADES PARALLEL TO
 LONG DIMENSION AND END BLADES PARALLEL TO SHORT
 DIMENSION
 IN TEE BAR FRAME FOR MODULAR CEILING APPLICATION

EXTRUDED ALUMINUM; 6063-T5

FINISH - SA (CLEAR ANODIZE) OR W (WHITE PAINTED)

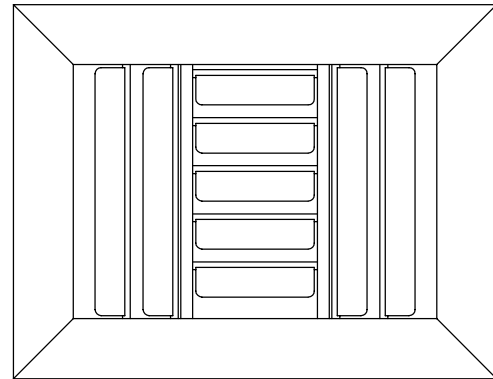

FACE VIEW

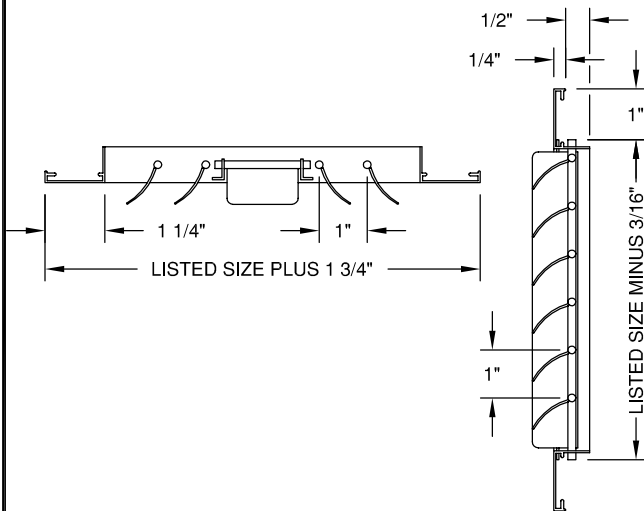

MODEL - C3TB - 3 WAY TEE BAR - GRILLE

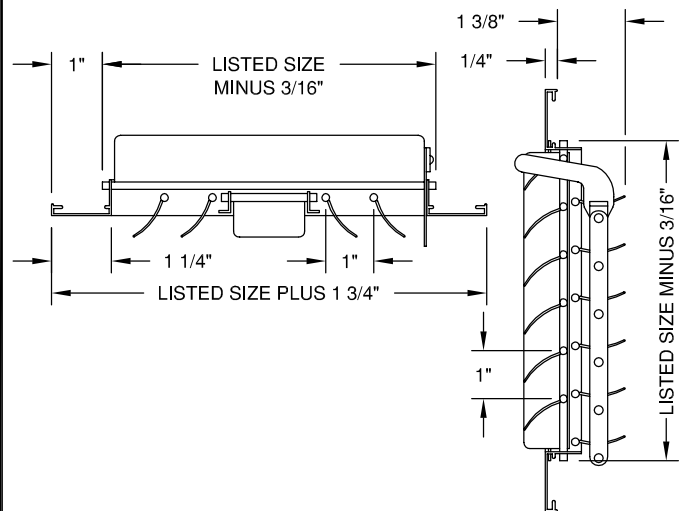

MODEL - C3MTB - MULTI-SHUTTER DAMPER

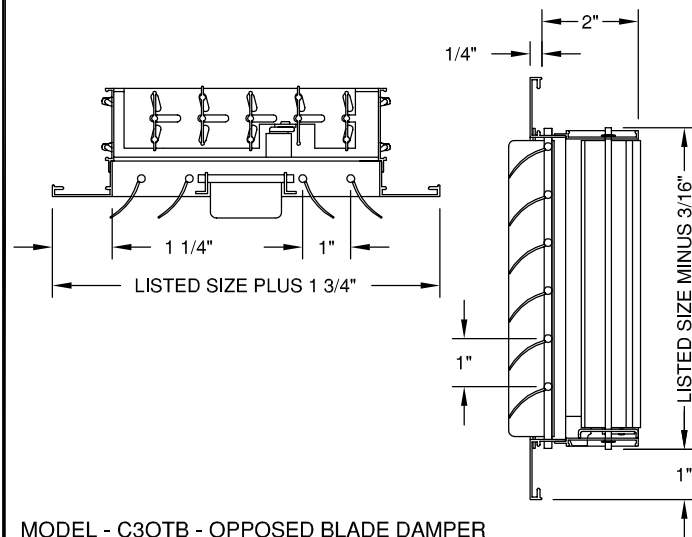

MODEL - C3OTB - OPPOSED BLADE DAMPER

T-BAR	LISTED SIZE	OVERALL
12 x 12	10 x 10	11 3/4 x 11 3/4
24 x 12	22 x 10	23 3/4 x 11 3/4
36 x 12	34 x 10	35 3/4 x 11 3/4
24 x 24	22 x 22	23 3/4 x 23 3/4
36 x 24	34 x 22	35 3/4 x 23 3/4
36 x 36	34 x 34	35 3/4 x 35 3/4

SIZE SCHEDULE

DWG NO. 02HV008A	JOB NAME: _____	ENGINEER: _____
DATE: 2/11/02	LOCATION: _____	CONTRACTOR: _____
	ARCHITECT: _____	FINISH: _____