

CURVED BLADE CEILING DIFFUSERS

INDIVIDUALLY ADJUSTABLE BLADES ON 1" CENTERS
4-WAY AIR DISTRIBUTION

MINIMUM SIZE: 6" WIDTH x 4" HEIGHT

MAXIMUM SIZE: 36" WIDTH x 36" HEIGHT

EXTRUDED ALUMINUM; 6063-T5

FINISH - SA (CLEAR ANODIZE) OR W (WHITE PAINTED)

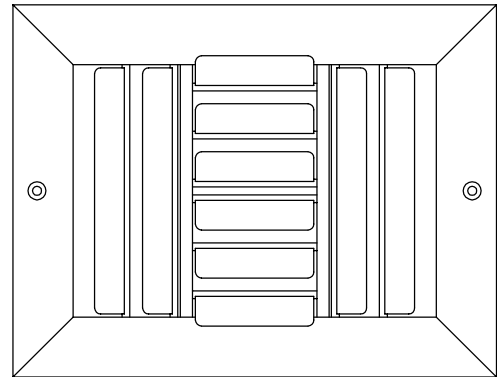

FACE VIEW

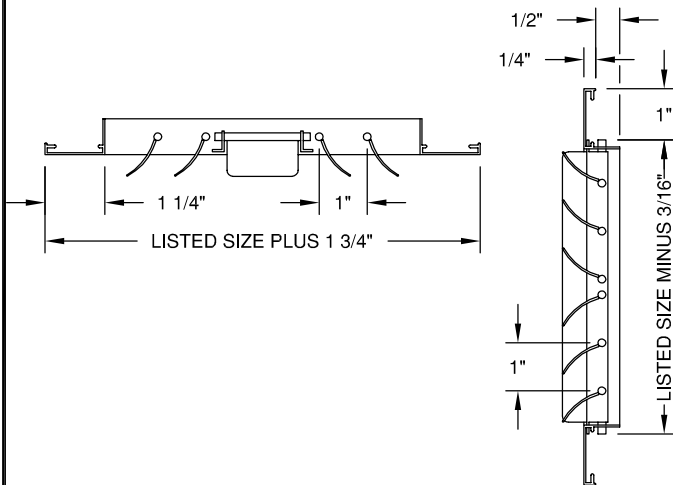

MODEL - C4 - GRILLE

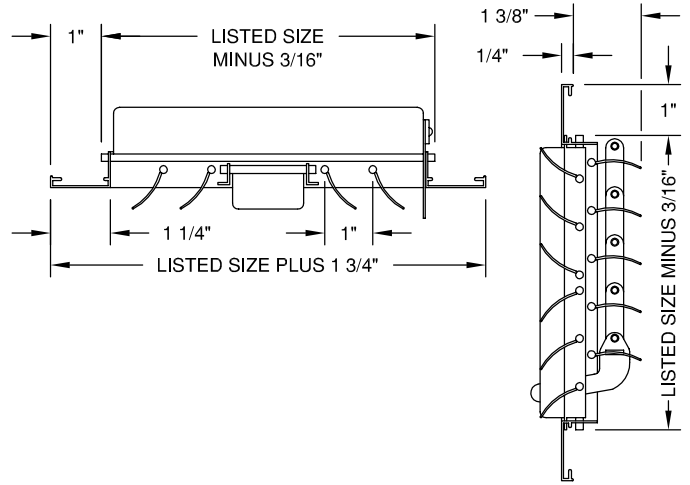

MODEL - C4M - MULTI-SHUTTER DAMPER

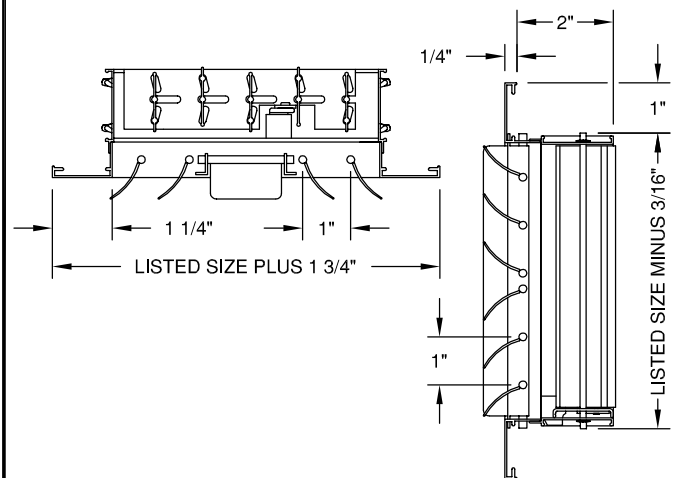

MODEL - C4O - OPPOSED BLADE DAMPER

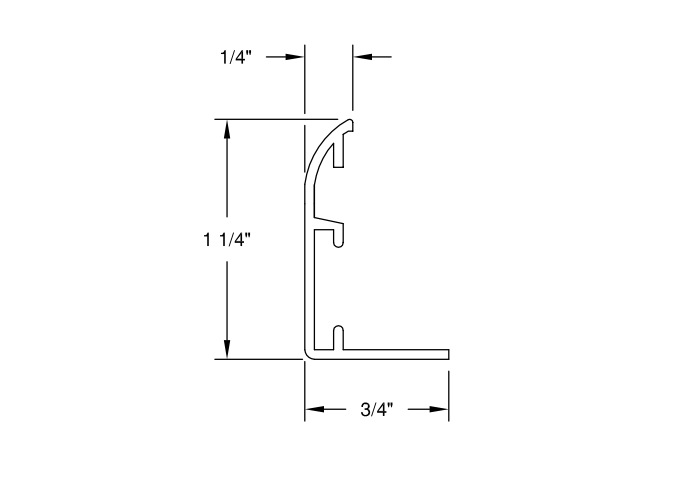

ALTERNATE "Z" FRAME

DWG NO. 02HV010A	JOB NAME: _____	ENGINEER: _____
DATE: 2/11/02	LOCATION: _____	CONTRACTOR: _____
	ARCHITECT: _____	FINISH: _____